

1. PRODUCT PROFILE



Figure 1.1 : Front view

2. DESCRIPTION

- EXP FLEX 2M is an expansion module for use in conjunction with specific Selec PLCs (with RS485 Master Communication)
- Use to enhance I/O Configuration
- Any Flexys I/O card can be configured (one per device)
- Upto 7 numbers of EXP FLEX 2M devices can be connected to a Master PLC
- Two baud rate selections - 19200 & 115200
- RS485 Slave IN & OUT separate terminals (for easy loop & wiring)
- 4 LED indicators
- Four way DIP switch for Slave ID & Baud rate selection

3. ELECTRICAL SPECIFICATIONS

| | |
|-----------------------------|--|
| Supply Voltage | 24VDC ±10 % |
| Power Consumption | 2.5 W |
| Reverse polarity protection | Yes |
| Isolation | No (between power circuit and communication circuit) |

FUNCTIONAL SPECIFICATIONS

| | |
|---------------|---|
| Response Time | 100 ms to 2 sec based on number of EXP FLEX 2M devices configured + I/O card type |
|---------------|---|

DIP SWITCH SELECTION

| Slave ID | DIP SWITCH | | | |
|------------------|------------|-----|-----|-----|
| | 1 | 2 | 3 | 4 |
| NA | | OFF | OFF | OFF |
| 1 | | OFF | OFF | ON |
| 2 | | OFF | ON | OFF |
| 3 | | OFF | ON | ON |
| 4 | X | ON | OFF | OFF |
| 5 | | ON | OFF | ON |
| 6 | | ON | ON | OFF |
| 7 | | ON | ON | ON |
| Baud Rate | | | | |
| 19200 | OFF | X | X | X |
| 115200 | ON | X | X | X |

LED Display

| LED Name | LED COLOR | INDICATION |
|-------------------|-----------|--|
| Power LED (PWR) | Green | Always ON when device is powered |
| Receive LED (Rx) | Green | Blinks when EXP FLEX 2M device receives RS485 command from master |
| Transmit LED (Tx) | Red | Blinks when EXP FLEX 2M device transmits RS485 response to master |
| Error LED (Err) | Red | ON – when I/O card is not connected |
| | | Flashing – 2 sec ON, 0.3 sec OFF – when I/O card is mismatched *1 |
| | | Flashing – 0.3 sec ON, 0.3 sec OFF – when No Master communication is received for 6 secs |
| | | OFF – successful operation |

*1 : When configured I/O card in SELPRO software is different from connected I/O card in EXP FLEX 2M

COMMUNICATION

| | |
|-------------------------|--|
| Communication Port | RS485 slave |
| Communication Protocols | Proprietary |
| Baud Rate | 19200 and 115200 (User configurable) (Default = 19200) |
| Fixed settings | Parity = None(N), Stop bits = 1, Data length = 8 |

MECHANICAL SPECIFICATIONS

| | |
|-----------------------|-----------------------|
| Dimension (W x H x D) | 35 mm x 90 mm x 88 mm |
| Weight (g) | 87.1 |
| Mounting | Din Rail Mounting |

ENVIRONMENTAL CONDITIONS

| | |
|---------------------------|---------------|
| Operating Temperature | 0° to 50°C |
| Storage Temperature | -20° to 70°C |
| Humidity (non-condensing) | 10% to 95% RH |

SOFTWARE DETAILS

R : Read only

- Configure EXP FLEX 2M device for a given Controller using SELPRO programming software.
For details of the software and configuration method, please refer to the software manual.
- Auto generated registers in SELPRO software as shown below :
Example : FL-SC-RO08 card is configured in EXP FLEX 2M device via SELPRO software with Slave ID=1.

| Register Name | Attributes | Description |
|--------------------|------------|--|
| ER_MOD_ID_U1 | R | I/O card module ID (unique for each type of I/O card) |
| ER_EXP_VerNo_U1 | R | Expansion module version number |
| ER_IO_VerNo_U1 | R | I/O card version number |
| ER_SlotStatus_U1 | R | Slot Status S=0 : refers to Slot empty S=15 : refers to Slot ready S=Other than 0 and 15 : Contact Vendor |
| ER_SlotErrorCnt_U1 | R | Slot error counter |
| ER_Modbus Error_U1 | R | Modbus communication error (0 / 10 = communication OK) |
| ER_R08_OUT0_U1 | R | Card specific Variables |
| ER_R08_OUT1_U1 | R | |
| ER_R08_OUT2_U1 | R | |
| ER_R08_OUT3_U1 | R | |
| ER_R08_OUT4_U1 | R | |
| ER_R08_OUT5_U1 | R | |
| ER_R08_OUT6_U1 | R | |
| ER_R08_OUT7_U1 | R | |

4. INSTALLATION PROCEDURE

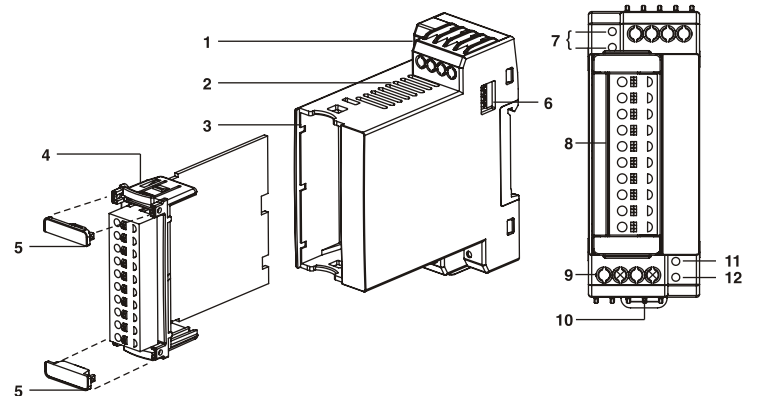

| | | | |
|---|------------------------|----|--|
| 1 | Communication Ports | 7 | Communication Status Indicator |
| 2 | Ventilation grills | 8 | Spring type pluggable terminal block (5.08 mm pitch) |
| 3 | Slot for FL-SC-XX card | 9 | Power Supply Connector |
| 4 | Fascia | 10 | Clamp |
| 5 | Card lock | 11 | Power Indicator |
| 6 | DIP Switch Selector | 12 | Error Indicator |

- NOTE** : 1) When installing, insert the card into the slot until you hear an audible click.
2) Ensure that I/O card installed is same as the one defined in Ladder Program.
3) Place Card lock to prevent movement of card from base unit.
Follow these steps to remove the I/O card from base unit :
1. Remove both the Card locks
2. Press at the top and bottom part of fascia and pull the card from base unit.

⚠ DANGER

1. Do not install in areas with excessive or conductive dust, corrosive or flammable gas, moisture or rain, excessive heat, regular impact shocks or excessive vibration.

5. DIN RAIL MOUNTING / DIMENSION

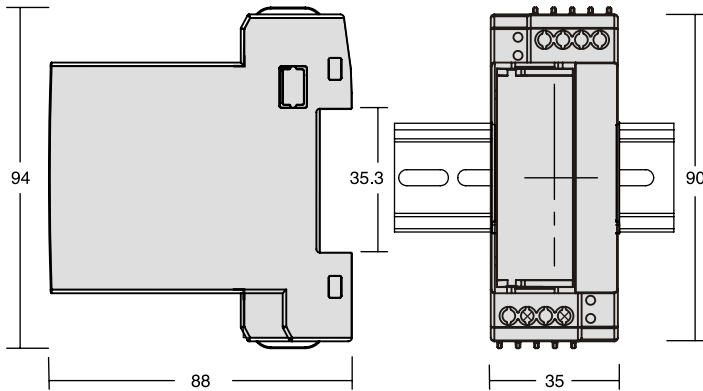

Dimensions in mm

- Install the device in an enclosure with sufficient space around it to allow heat dissipation,
- Be sure to use DIN rail clamp to stop movement of the device.
- The clamp is at the bottom of the device. To secure the device to DIN rail, Push down the device until it click.
- To remove the device, pull the clamp down with a flat screwdriver and gently pull the device up to remove from DIN rail.

6. WIRING DETAILS

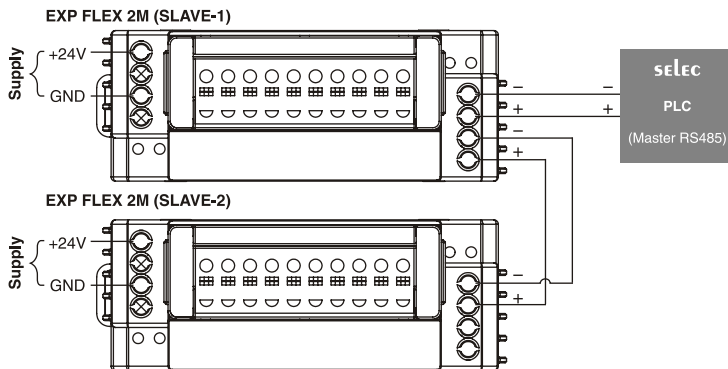

⚠ CAUTION

- In situations of high transmission speed, long distance or high noise, the high quality twisted pair cable should be used. However in situations of low transmission speed and low noise, PVC twisted pair cable will be compatible.
- The laying of cables on ventilation grills is not permitted. This would considerably impede the heat dissipation of the devices.

⚠ WARNING

- Analog I/O wiring length to be restricted up to 3 m.
- The power supply connection cable must have a cross section of 1sq.mm or greater and insulation capacity of at least 1.5 kV.

WIRING INSTRUCTIONS

- In PLC control system, many devices are controlled at the same time and actions of any device could influence each other, i.e., breakdown of any device may cause the breakdown of the entire auto-control system and danger. Therefore, we suggest you wire a noise protection circuit at the power supply input terminal.
- Use the shortest possible wire length.
- Use wire trays for routing where possible.
- To minimize voltage drops when wires must run a long distance, consider using multiple wires for the return line.
- Avoid running lower voltage wiring near higher voltage wiring.
- Avoid running input wiring close to output wiring where possible.
- Avoid running DC wiring in close proximity to AC wiring where possible.
- Avoid creating sharp bends in the wires.
- The output terminals should not be loaded more than the values/range specified by the manufacturer.
- Always use a continuous length of wire. Do not splice wires to attain a needed length.

7. SAFETY SUMMARY

⚠ DANGER

Indicates that death or severe personal injury will result if proper precautions are not taken.

⚠ WARNING

Indicates that death or severe personal injury may result if proper precautions are not taken.

⚠ CAUTION

With a safety alert symbol, indicates that minor personal injury can result if proper precautions are not taken.

NOTE :

Indicates that an unintended result or situation can occur if the relevant information is not taken into account.

SAFETY PRECAUTIONS

- This manual is meant for person involved in wiring, installation and operation of the equipment.
- Safety related conditions, symbols & instructions that appear in this operating manual or on the equipment must be strictly followed to ensure operator's and instrument's safety.
- Commissioning is absolutely prohibited until it has been completely ensured that the machine, in which the components described here are to be installed, is in full compliance with the provisions of the EC Machinery Directive.

⚠ DANGER

- Failure to comply with appropriate safety guidelines can result in severe personal injury or property damage. Always exercise proper caution when working with electrical equipment.
- Improper grounding may result in communication error, electric shock or fire.

⚠ WARNING

- Read complete instructions prior to installation and operation of the controller/card
- Proper transport, storage, installation, assembly, commissioning, operation and maintenance are required to ensure that product operate safely and without any problem.

⚠ CAUTION

- In addition to the danger and warning information provided in the manual, the applicable national, local and system specific regulations and requirements must be taken into account.
- If product and components from other manufacturers are used, these must be recommended or approved by SELEC Controls Pvt Ltd.

EMC GUIDELINES

- The permissible ambient conditions must be complied
- Power supply lines length to be maintained within 10m.

MAINTENANCE

- To avoid blockage of ventilation grills, clean the equipment regularly using a soft cloth.
- Do not use Isopropyl Alcohol or any other organic solvents for cleaning.
- Conductors must not come in contact with the internal circuitry of the controller or else it may lead to a safety hazard that may cause electrical shock to operator.

DISCLAIMER LIABILITY

We have reviewed the contents of this publication to ensure consistency with the hardware and software described. Since variance cannot be precluded entirely, we cannot guarantee full consistency. However the information in this publication is reviewed and any necessary corrections are included in subsequent editions.

? SERVICE DETAILS

This device contains no user serviceable parts and requires special equipment and specialized engineers for repair.

Please contact service center for repair on the following numbers :

Tel. No. : + 91-7498077172 ; **Email :** service@selec.com

NO WARRANTY ON UNIT DAMAGED DUE TO WRONG POWER SUPPLY.

(Specifications are subject to change, since development is a continuous process.)

Selec Controls Pvt. Ltd., India

Factory Address :

EL-27/1, Electronic Zone, TTC Industrial Area, MIDC, Mahape, Navi Mumbai - 400 710, INDIA.

Tel. No. : +91-22-4148 419/430 | Fax No. : +91-22-28471733

Toll free : 1800 227 353 (BSNL/MTNL Subscribers only)

Website : www.selec.com | Email : sales@selec.com